Manual

Universal Switch Mounting System



AbleNet Tools for Independence

AbleNet designs and manufactures tools for independence, products and services that allow people with severe disabilities to participate more fully in daily activities at home, school, work and in their communities.

AbleNet products help children and adults communicate and control electrical and battery-operated appliances, toys, and devices. AbleNet also provides workshops, written materials, and information that support and assist families, teachers, therapists and care providers worldwide.

For more information about AbleNet products and services visit us online at www.ablenetinc.com or call 1-800-322-0956.

AbleNet, Inc.
Minneapolis • St. Paul
Minnesota

Introduction

The Universal Switch Mounting System (USMS) allows you to position a switch (or whatever you are mounting) at any angle with the action of a single lever or knob. When you release the side lever or turn the knob of the adjustable arm, you can move the central lock and both ball and socket joints into any position. Lock the side lever into position or tighten the knob and all the joints become stationary.

Your Universal Switch Mounting System includes the adjustable arm, a one-piece Clamp which tightens onto many different surfaces, and a Mounting Plate to secure a switch or other device to the USMS. The USMS with lever includes two allen wrenches for periodic adjustment as needed.

Warranty

AbleNet manufactured products include a two-year limited warranty. This warranty is against defects in materials and manufacturing for two-years from the date of purchase. Warranty in full text, along with return/repair information is available at www.ablenetinc.com. For warranty and repair outside the United States please contact your local AbleNet reseller. For more information on AbleNet products and services, contact: AbleNet, Inc. Minneapolis/St. Paul, MN | 800-322-0956 | www.ablenet-inc.com

AbleNet, Inc. Repair Information

AbleNet corded switches are warranted for three years; all other AbleNet manufactured products are warranted for one full year from the date of purchase. If documentation identifying the date of purchase is not supplied, the warranty period will be determined as one year from the manufacture date stamped inside the product.

All products under warranty are repaired free of charge. Products no longer covered by warranty may be repaired for a nominal fee. All repairs are warranted for 90 days. Before sending in a product for repair, please contact an AbleNet customer service representative for a Return Authorization Number (RA#) and repair charge, if applicable.

To have a product repaired, please include the following with your product:

- Name and phone number
- RA#
- Return shipping address
- Brief description of the problem (what the product is or isn't doing, along with what has already been done to correct the problem)
- Documentation that shows the purchase date (i.e., copy of packing slip, purchase order, or invoice)
- Check, money order, or purchase order for the amount of repair

Call 1-800-322-0956 for a Return Authorization Number

3. Using the small allen wrench, loosen the Set Screw—located inside the Lever—by turning it **counter clockwise** one or two turns only.
4. With the larger allen wrench, tighten the Bolt Head of the Central Lock—opposite of Set Screw—by turning it **clockwise**. Tighten just until the arm does not move easily. It should still be in an unlocked position.
5. To *fine tune* your adjustment, now loosen the Bolt Head— the one you just tightened— by turning it **counter clockwise** until the extended arm drops slightly under its own weight.
6. Tighten the Set Screw (inside the Lever) by turning **clockwise** until it feels firm against the bolt.

The Extended Arm should now swing freely. Move the Lever to lock the USMS into the desired position. If you have any questions about adjusting your USMS or are still having problems with it after adjustment, please call us at 800-322-0956. **DO NOT attempt to take your USMS apart.**

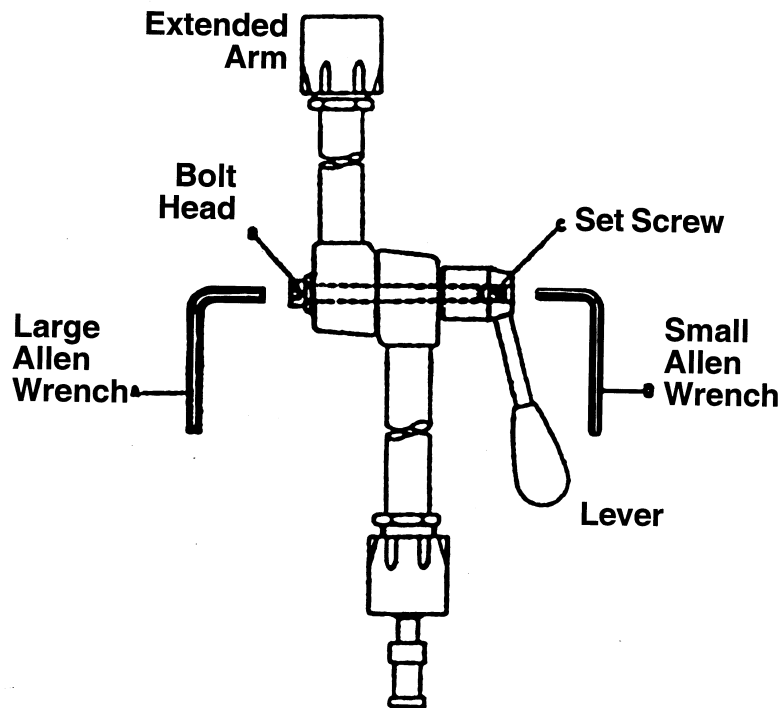

Assembling Your USMS

To assemble your USMS, follow the steps outlined below.

1. Attach the Clamp to a secure surface (see Diagram 1).

On flat surfaces, remove the Wedge from around the Locking Screw (Diagram 1a), and place the wedge angle into the inverted “v” shape surface of the Clamp (Diagram 1b). Hold the top portion of the Clamp tightly against the surface and turn the Clamp Securing Handle until the Clamp is stationary.

On rounded surfaces, such as a wheelchair frame, place the right angle (the inverted “v” shape) surface of the Clamp against the rounded edge and turn the Clamp Securing Handle until the Clamp is secure. The Wedge is not needed with rounded surfaces.

2. Push the Ann Release Button (on side of Clamp) and place the adjustable arm into the Clamp. **NOTE:** Make sure that the Bottom Arm (the arm piece that attaches to the Central Lock- see diagram) end is inserted into the Clamp. As a quick reference, look for the AbleNet label- the labeled end goes into the Clamp.

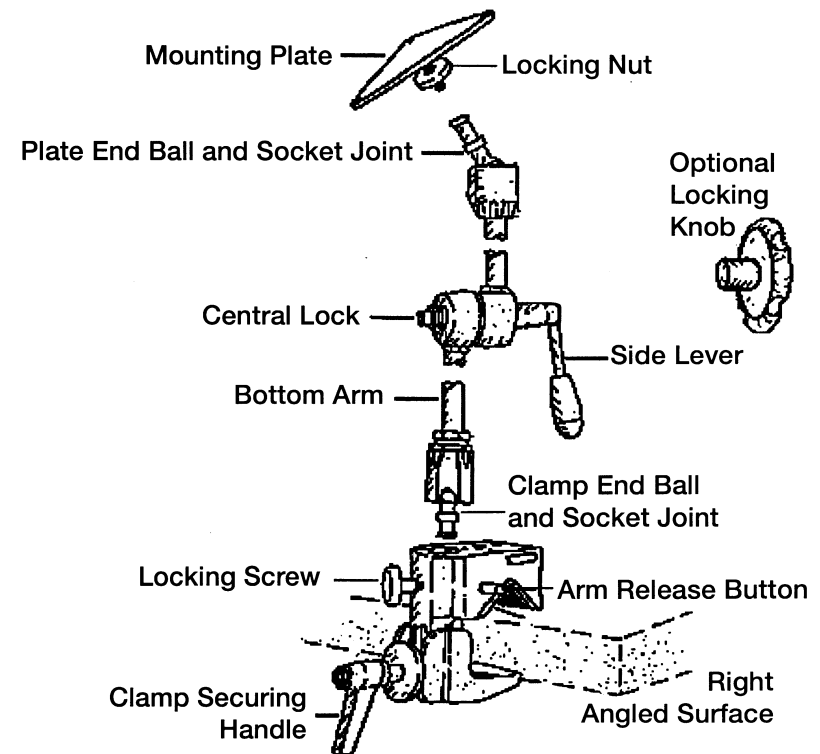
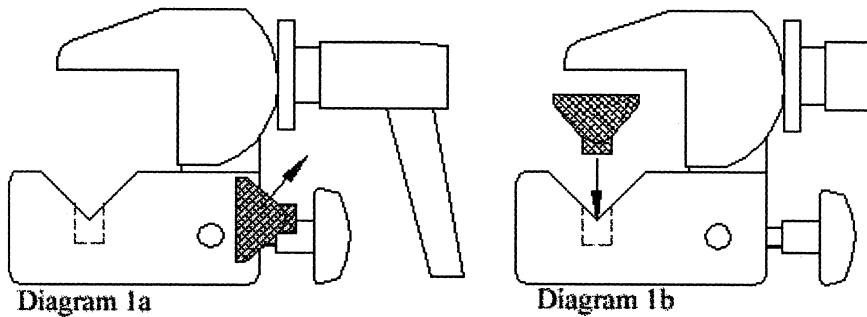

Diagram 1: Universal Mounting Switch



3. Tighten the locking screw on the Clamp until the arm is secure in the Clamp.
4. Screw the Mounting Plate three or four rotations into the top joint of the adjustable arm. Then turn the Locking Nut (stabilizing the Mounting Plate) until it makes contact with the top joint of the adjustable arm.

Attaching Switches or Other Devices to the USMS

AbleNet offers a variety of Mounting Plates that make it easy to mount many kinds of switches or other devices to the USMS. Your USMS is shipped with a large triangular plate unless you specify another plate at the time of your order. If the Mounting Plate you received with your USMS is incorrect, please call Customer Service at 800-322-0956. Choose the Mounting Plate that offers the most stability for the device you are mounting. Do not use a Mounting Plate that is too large, as protruding edges can be distracting and dangerous.

Positioning a Switch or Device

In a fully extended position, the USMS will support five pounds of weight. To position a switch or other device mounted to the USMS, follow the steps below.

1. Unlock and loosen mounting system joints.
 - **USMS with lever:** Unlock the side lever of adjustable arm to loosen all joints. To unlock the side lever, rotate the handle left until it points up. (Imagining a clock face, the side lever is unlocked at 12 o'clock, pointing straight up.)
 - **USMS with friction knob:** Unlock the knob by turning it to the left. NOTE: Joints of the mounting arm will loosen in direct relation to how much you turn the knob.
2. Move the switch or device into the position you want and hold it there while you lock the side lever or knob.

3. Lock the mounting system joints.

- **USMS with lever:** To lock the side lever, turn the lever right as far as it will go. (Again, imagining a clock face, the side lever is locked at 8 o'clock.) NOTE: To ensure the USMS is fully locked, make sure the side lever is ALL the way to the 8 o'clock position.
- **USMS with friction knob:** Lock the knob by turning it to the right. The knob will be securely locked when it will no longer turn.

Safety Considerations

Check the security of all joints and connections before the individual uses the system. If using the USMS with lever, make sure the side lever is locked in the 8 o'clock position. If using the USMS with friction knob, make sure that the knob can no longer be turned to the right.

Position the switch or other device on the Mounting Plate so that the user will not come into contact with the corners of the plate.

If the Central Lock on the USMS with lever becomes loose after a period of use, refer to **Adjusting the USMS**.

NOTE: No adjustment is needed for the USMS with friction knob.

Adjusting the USMS (with lever only)

After the USMS has been used for a while, you may notice that the locking mechanism seems looser than it was when you first received it. This is normal. After a period of use, the locking mechanism will loosen and will need adjustment. For optimal performance, adjust your USMS every few months (depending on use).

Indications that your USMS needs adjustment are:

- A loud, audible snap or popping sound when locking or unlocking the USMS
- Failure of any of the joints to hold their position when the USMS is locked.

To adjust (tighten) your USMS, see Diagram 2 and follow the steps below, using the two allen wrenches (sizes, metric numbers 4 and 6) supplied with the USMS.

1. Remove all accessories (including the Mounting Plate and Clamp) and unlock the mounting system.
2. Hold the USMS so the Bolt Head is on your left and the Lever is on your right (Diagram 2). Position the arm of the USMS to form an upside down "L" (arms at a 90 degree angle).